



REVERSIBLE COMPACTOR

MVH-R60

MVH-120

MVH-150

INSTRUCTION MANUAL



Contents of "Declaration of Conformity"

Please refer the
EC DECLARATION OF CONFORMITY
in this manual as well.

We thank you for selecting Mikasa
Vibration Compactor. For your safe
and proper operation, please read
this manual and be always sure to
keep it ready for reference.

Original



MIKASA SANGYO CO.,LTD.

402-04504

1) DECLARATION OF CONFORMITY

2) Manufacturer's name and address.		Mikasa Sangyo Co., Ltd. 4-3, Sarugaku-cho 1 chome, Chiyoda-ku, Tokyo101-0064, Japan				
3) Name and address of the person who keeps the technical documentation.		Yoshiharu Nishimaki, engineer R. & D. Division, Mikasa Sangyo Co., Ltd. Shiraoka-machi, Saitama, Japan				
4) Type: Vibratory Plates						
5) model	MVH-R60	MVH-120GH	MVH-120GR	MVH-150GH	MVH-150GR	MVH-150D
6) Equipment item number	452726 452732 452733	452802 452806 452814	452810 452811	452772 452776 452778	452762	452758
7) Serial number	For serial number, please refer it on front page.					
8) power source cont. output <max.output>	Honda GX120 2.1kW <2.6kW>	Honda GX160 2.9kW <3.6kW>	Robin EH17 2.9kW <3.7kW>	Honda GX200 3.7kW <4.1kW>	Robin EH25 4.7kW <5.9kW>	Yanmer L48N 3.1kW <3.5kW>
9) Measured sound power level(dB)	104	107	106	107	107	107
10) Guaranteed sound power level(dB)	105	108	108	108	108	108
11) Max. Sound pressure level(dB)	90	94	94	94	97	95
12) Conformity assessment according to Annex:	VIII (Full Quality Assurance procedure)					
13) Name and address of the Notified Body	Société Nationale de Certification et d'Homologation (SNCH) 11, route de Luxembourg L-5230 Sandweiler LUXEMBOURG					
14) Related Directive	Directive 2000/14/EC and, to be followed by Directive 2005/88/EC , relating to the noise emission in the environment by equipment for use outdoors.					
15) Declaration	The equipment referred in this document, fulfills with all the requirements of Directive 2000/14/EC					
16) Other related Community Directives	2006/42/EC, 2005/88/EC, 2004/108/EC, 2002/88/EC(2004/26/EC) EN500-1, EN500-4					
17) EC Conformity Certificate No:	e13*2000/14*2005/14*0472*01					
18) Place and date of the declaration	Tokyo, Japan Jul, 2010 Signed by:  Keiichi YOSHIDA Director, Product Control Division Mikasa Sangyo Co., Ltd.					

TABLE OF CONTENTS

1. Preface.....	1
2. Applications, Warnings, Power Transmission of Machine	1
3. Warning Symbols	3
4. Safety Precautions	3
4-1 General Precautions	3
4-2 Refueling Precautions	4
4-3 Location and Ventilation Precautions	4
4-4 Precautions Before Starting	4
4-5 Precautions During Work	4
4-6 Lifting Precautions	4
4-7 Transportation and Storage Precautions	5
4-8 Maintenance Precautions	5
4-9 Labeling Positions	6
4-10 Description of Symbols Used on Warning Labels	7
5. Specifications	9
6. Appearance.....	10
6-1 Outside Dimensions.....	10
6-2 Parts and Component	11
7. Inspection Before Operation.....	12
8. Operation.....	13
8-1 Starting	13
Gasoline Engine	13
Diesel Engine	16
8-2 Operation	17
9. Stopping the Machine.....	18
10. Transportation	19
10-1 Loading and Unloading	19
10-2 Transportation Precautions	19
11. Storage.....	19
12. Regular Check and Adjustment	20
12-1 Inspection and Maintenance Schedule Table.....	20
12-2 Changing the Engine Oil.....	21
12-3 Cleaning the Air Cleaner.....	21
12-4 Checking/Changing the V-belt and Clutch.....	21
12-5 Checking/Changing the Vibrator Oil.....	22
12-6 Checking/Changing the Hydraulic Oil.....	22
13. Troubleshooting	24
13-1 Gasoline Engine.....	24
13-2 Diesel Engine	25
13-3 Main Body	26

1. Preface

This operation manual describes the proper operation, basic inspection and maintenance procedures of the reversible compactor. Please read this operation manual before use in order to maximize the excellent performance of this machine and make your work more efficient and effective.

After reading the manual, please keep it in a handy location for easy reference.

For the handling the engine, please refer to the separate engine operation manual.

For inquiries about repair parts, parts lists, service manuals, and repairs, please contact the store where you purchased the product, our sales office, or the Mikasa Parts Service Center. For parts lists, please visit our homepage at: <http://www.mikasas.com/> where you can access Mikasa WEB parts lists.

<p>The illustrations in this manual might slightly differ in part from the machine you actually purchased due to design changes.</p>

2. Application, Warnings, Power Transmission of Machine

Application

This machine, weighing more than 60kg to more than 150kg, is a compactor with back and forth motion. The strong vibration from the two-axes pendulum structure inside the vibrator changes the machine's motion into straight back and forth motion. The machine compacts through this motion.

The machine has tightening and compacting effect for all ground types other than the soft soil with high water percentage. Because the machine is capable of straight back and forth movement, it works very effectively in grooved structures. Also, since the work efficiency of this machine is high, it is suitable for compacting of a large area. The machine also works well for flattening and leveling rough ground surface with irregularities created by the use of a powerful tamping rammer.

The machine can be used widely for heavy compacting works such as base work as well as finishing work for asphalt paving.

Warning about Incorrect Applications and Techniques

Do not use this machine on ground with a high water percentage and, in particular, do not use on clay because the machine will not advance. Use this machine for compacting earth and sand mixtures, soil, sand or gravel. Do not use this machine for other type of work.

Structure

The upper part of the machine consists of an engine, handle, belt cover and guard frame. The upper part of the machine is fixed to the compacting board of the lower part via an anti-vibration rubber. The lower part of the machine consists of a compacting board and a vibrator. Inside the vibrator, there are two pendulums. The phase of those pendulums is changed by hydraulic pressure.

The hydraulic cylinder for the vibrator is connected with a hydraulic hose to the hydraulic pump, which is directly connected to the drive lever.

Power Transmission

Power is provided by an air-cooled single-cylinder 4-cycle gasoline engine or diesel engine. The engine output shaft is equipped with a centrifugal clutch. The centrifugal clutch is engaged when the engine speed increases. A V-pulley is incorporated to the centrifugal clutch drum, and power is transmitted via the V-belt to the V-pulley on the vibrator side.

Through this process, the engine revolution is changed to the pendulum revolution suitable for compacting.

The vibrator pulley rotates the pendulum axis of the drive side. The two pendulums inside the vibrator are fixed to the two pendulum axes that are positioned in parallel and are connected with the gear. The two axes rotate in opposite directions at the same speed to generate vibration.

There is a spiral groove on the inner periphery of the gear assembled on the pendulum axis to be driven. This groove serves as a key groove to let the guide pin slide to the axis direction. This guide pin is connecting the two pendulum axes. The phase of the two pendulums is changed by the axial sliding of the guide pin. The change in phase causes the vibration to change directions, thus changing the speed and travel direction of the machine.

Hydraulic pressure is used for the axial movement of the guide pin. At the end of the groove where the guide pin is attached, a piston is installed. When the oil level rises inside the hydraulic cylinder on the vibrator side and the pressure increases, the piston is pushed. Then the axis connected to the piston is pushed, which causes the guide pin attached to the axis to move, resulting in a change in phase.

The operator of the machine, by using the back and forth motion lever of the handle, can adjust the oil quantity and pressure by the connected hand pump to get the travel speed suitable for the work.

3. Warning Symbols

The triangle marks(⚠) used in this manual and on the decals on the machine are warning symbols. Please follow these precautions.

⚠ Warning symbols indicating personnel hazards

⚠ **DANGER:** Extremely hazardous. If the warning is not followed, it is likely to result in serious injury or death.

⚠ **WARNING:** Hazardous. If the warning is not followed, it is likely to result in serious injury or death.

⚠ **CAUTION:** Potential hazard. If the warning is not followed, it may result in injury.

Precautions (without ⚠ mark): If the warning is not followed, it may result in property damage.

4. Safety Precautions

4-1. General Precautions

⚠ **WARNING**

- **DO NOT** operate the machine,
 - If you do not feel well due to overwork or illness.
 - If you are taking any medicine.
 - If you are under the influence of alcohol.

⚠ **CAUTION**

- Read this manual carefully and handle the machine as described to ensure safe work.



- For details about the engine, refer the separate instruction manual for the engine.
- Make sure you understand the structure of the machine well.

- For safe work, always wear protective gear (helmets, safety shoes, ear plugs, etc.) and work in appropriate clothes.



- Always check the machine before your work to make sure it is in normal condition.
- Decals on the machine (operation method labels, warning labels, etc.) are very important for your safety. Keep the machine clean so that the decals can be read all the time. Replace a decal if it becomes illegible.
- Before performing maintenance work, be sure to turn the engine off.
- It is very dangerous if children come into close contact with the machine. Have the utmost concern about how and where to store the machine. In particular, for an engine with a cell, always remove the starter key and keep it in a designated place.
- Before inspection and maintenance work, stop the engine, and do your work on a flat surface area. If a cell is attached, remove the battery wiring before your work.
- Mikasa does not accept any responsibility for accidents caused by remodeling or rework done on the machine.

4-2. Refueling Precautions

DANGER

- When adding fuel,
 - Make sure you work in a well ventilated location.
 - Make sure the engine is stopped and wait until it cools down.
 - Take the machine to a clear flat location without any combustibles nearby. Be careful not to spill the fuel. Wipe well if any spill occurs.
- Do not fill to the rim due to potential spillage.
- After adding the fuel, tightly close the tank cap



4-3. Location and Ventilation Precautions

DANGER

- **DO NOT** run the machine in an unventilated location, such as indoors or inside a tunnel. The exhaust gas from the engine contains toxic gases such as carbon monoxide and is very hazardous.
- **DO NOT** operate the machine near open flames.



4-4. Precautions Before Starting

CAUTION

- Check each part to see if it is tightened properly. Vibration causes loosening of bolts, which results in unexpected serious malfunctions of the machine. Tighten the bolts securely.

4-5. Precautions During Work

CAUTION

- Before starting the machine, make sure it is safe to start by checking your surroundings for people and objects.
- Always pay attention to your footing. Work in an area where you can maintain a good balance of the machine and a safe comfortable posture.
- The engine and muffler become very hot. Do not touch immediately after the machine stops because they are still very hot.
- If you notice deterioration of machine operation during your work, stop your work immediately.
- Before moving away from the machine, be sure to turn the engine off. Also when the machine is transported, stop the engine and close the fuel cock.



4-6. Lifting Precautions

DANGER

For unloading using a crane, a licensed crane operator is needed. An operator should be qualified for crane and hooking work.

- Before lifting, check the machine parts (especially the hook and anti-vibration rubber) for any damage and loosened or missing bolts.

Lifting Precautions (Continued)

- Stop the engine and shut the fuel cock while lifting.
- Use a sufficiently strong wire rope.
- For lifting, use only one point hoisting hook, and do not lift at any other part.
- When the machine is hoisted, never let people or animals come underneath.
- For safety reasons, do not lift to a height that is higher than necessary.

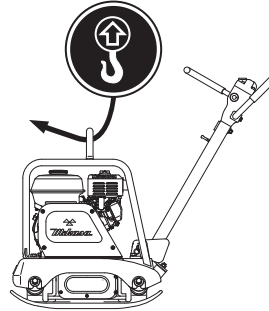

4-7. Transportation and Storage Precautions

WARNING

- Stop the engine during transportation.
- Transport after the engine and the machine are cooled down.
- Always drain the fuel before transporting.
- Securely fix the machine to prevent it from moving or falling during transportation.

4-8. Maintenance Precautions

WARNING

- Appropriate maintenance is required to ensure safe and efficient operation of the machine. Always pay attention to the machine's condition and keep it in good condition. Pay special attention to the parts used for lifting, if they are not maintained properly, it might result in a serious accident.
- Start maintenance work after the machine has cooled down completely. The muffler, in particular, becomes very hot, and there is a danger of burn. The engine, engine oil and vibrator also become very hot. Be careful not to get burned.

CAUTION

- Always stop the engine before inspection and adjustment. If you are caught in a rotating part, serious injury might occur.
- After maintenance work, check the security parts to see if they are securely installed. Special attention should be paid when checking bolts and nuts.
- If disassembly is involved in maintenance, refer to the maintenance instruction manual to make your work safe.

DANGER

- The gas from the battery might cause an explosion. Do not generate sparks or bring flames near the battery.



- Never put the positive terminal and negative terminal come into contact. Sparks will be generated, and ignition might occur.

WARNING

- Be careful when handling the battery fluid because it is very toxic. If the battery fluid gets on your skin, eye, or clothes, rinse it off with plenty of water and consult with a doctor.

4-9. Labeling Positions

MVH-R60
-120
-150

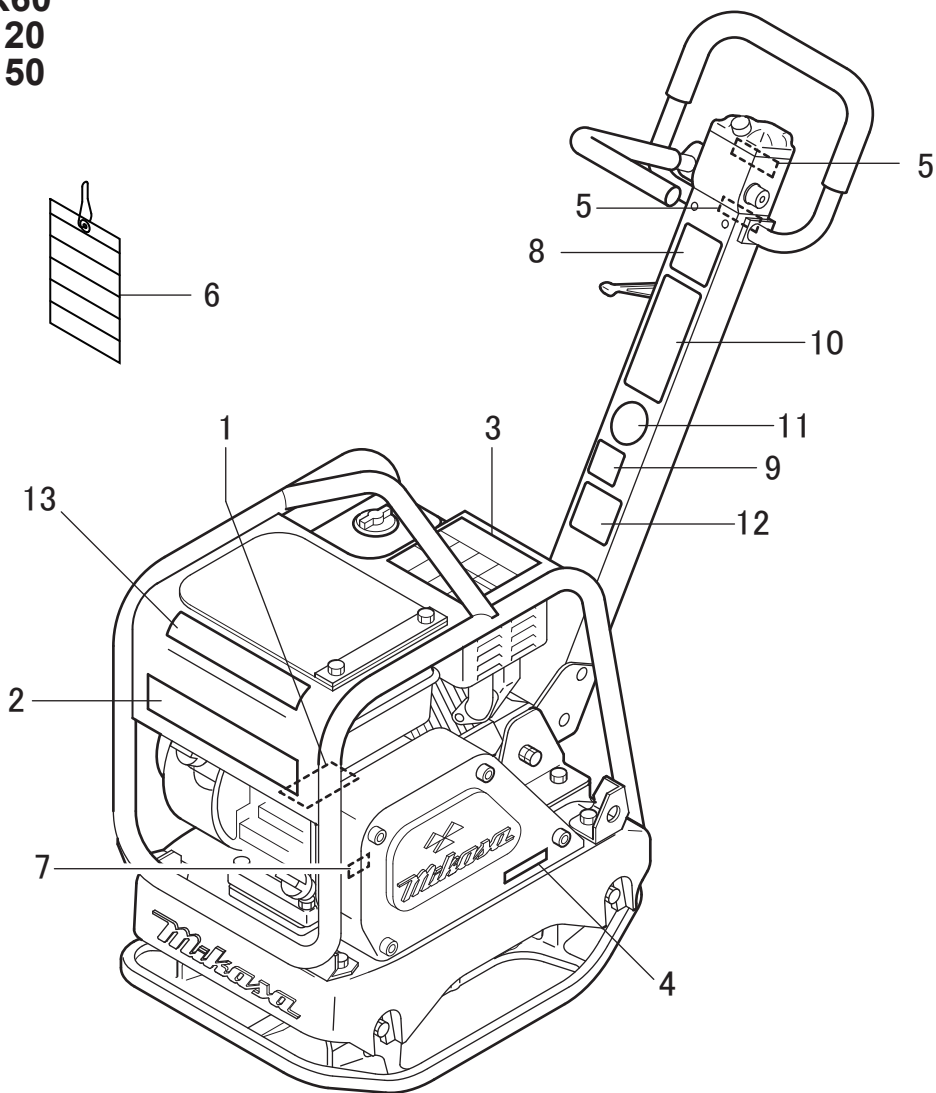

Label No.	Parts No.	Parts Name	Remarks
1	—	PLATE, SERIAL NO.	
2	9201-10000	DECAL, MODEL/MVH-R60	MVH-R60
2	9202-07440	DECAL, MODEL/MVH-120	MVH-120
2	9202-07660	DECAL, MODEL/MVH-150	MVH-150
3	9202-09620	DECAL, CAUTION/R60	MVH-R60
3	9202-07400	DECAL, DANGER-CAUTION/MVH-150	MVH-120/150
4	9202-07420	DECAL, V-BELT RPF-3320	MVH-R60/120
4	9202-07670	DECAL, V-BELT RPF-3350	MVH-150G
4	9202-07680	DECAL, V-BELT RPF-3340	MVH-150D
5	9202-07480	DECAL, SHELL TELLUS OIL 46	
6	9202-00870	DECAL, WITHOUT ENGINE OIL	
7	9202-01950	DECAL, OIL SAE 10W-30	
8	9202-10330	DECAL, EC NOISE REQ.LWA105	MVH-R60
9	9202-10100	DECAL, EC NOISE REQ.LWA108	MVH-120/150
10	9202-07430	DECAL, CAUTION/MVH-120	MVH-120/150
11	9202-03330	DECAL, EAR PROTECTION LABEL	MVH-120/150
12	9202-07690	DECAL, CAUTION/MANUAL	MVH-120/150
13	9202-09530	DECAL, CAUTION/COMBINATION	MVH-120/150

4-10. Descriptions of Symbols Used on Warning Labels

Label No.3 Pars No.9202-09620 (MVH-R60)

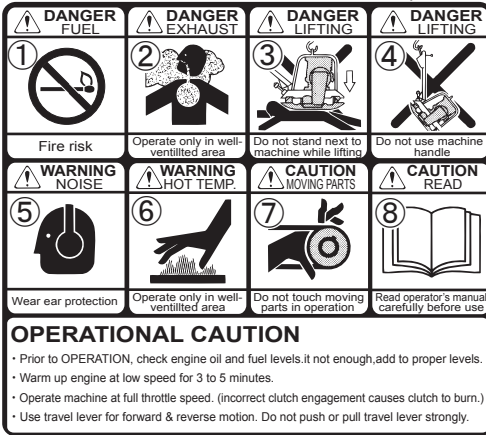

Label No.3 Pars No.9202-07400 (MVH-120/150)



※Engine type except L48

Label No.13 Pars No.9202-09530 (MVH-150 D [L48])



- (1) Fire hazard
Stop the engine when refueling. Fire may occur if a flame is near the tank fuel port.
- (2) Danger: poisonous exhaust gas
Carbon monoxide poisoning may occur if the exhaust gas is inhaled. Do not operate the machine in a poorly ventilated area.
- (3) Do not go under the lifted machine.
Do not let people or animals go under the lifted machine.
- (4) Lifting by the handle is prohibited.
Due to a falling risk, do not lift the machine by the handle.
- (5) Danger of hearing damage caused by noise
Always use ear plugs while operating the machine.
- (6) Be careful not to get burned.
Accidental burn may occur if you touch the hot parts (engine, muffler, etc.) during operation or immediately after the machine stops.
- (7) Be careful not to be caught in rotating parts.
Make sure the engine is stopped when removing the belt cover during a belt change.
- (8) Read the manual carefully.
Always read the operation manual and have good understanding of operation before your work.

Decal for new European machine directives

Part No. 9209-00110 DECAL, SET /MVH, MRH /EXP, EU

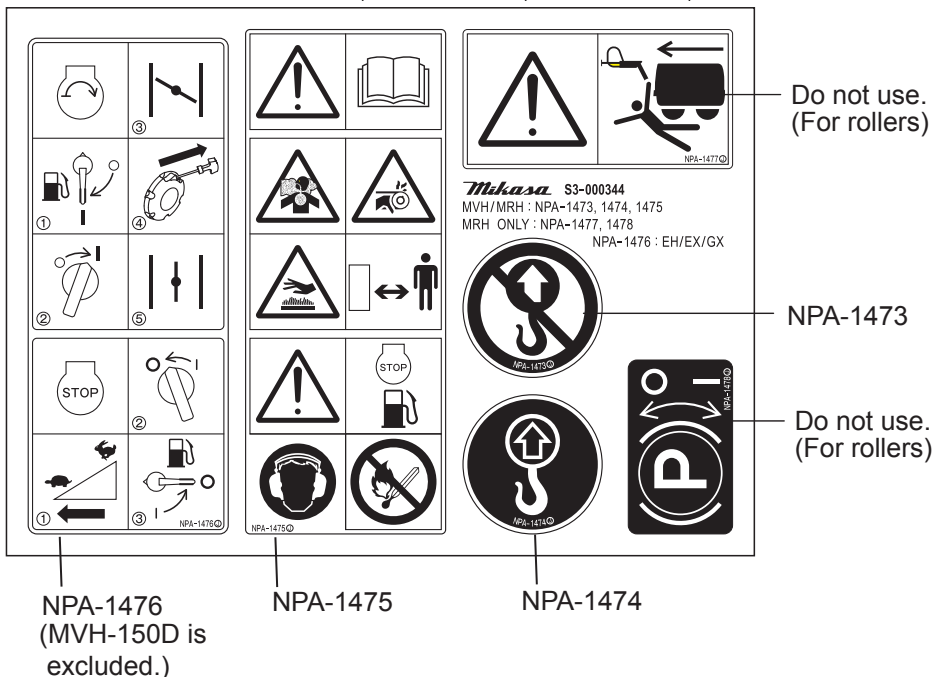

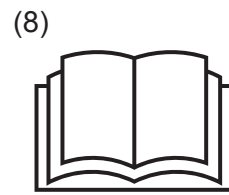
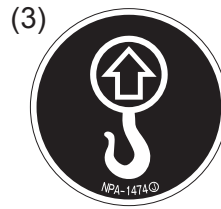

- (1) Fire hazard
Stop the engine when refueling. Fire may occur if a flame is near the tank fuel port.
- (2) Danger: poisonous exhaust gas
Carbon monoxide poisoning may occur if the exhaust gas is inhaled. Do not operate the machine in a poorly ventilated area.
- (3) Do not go under the lifted machine.
Do not let people or animals go under the lifted machine.
- (4) Lifting by the handle is prohibited.
Due to a falling risk, do not lift the machine by the handle.
- (5) Danger of hearing damage caused by noise
Always use ear plugs while operating the machine.
- (6) Be careful not to get burned.
Accidental burn may occur if you touch the hot parts (engine, muffler, etc.) during operation or immediately after the machine stops.
- (7) Be careful not to be caught in rotating parts.
Make sure the engine is stopped when removing the belt cover during a belt change.
- (8) Read the manual carefully.
Always read the operation manual and have good understanding of operation before your work.

Caution Decals on Engine

(MVH-150D is excluded. Refer to engine instruction manual for MVH-150D.)



Robin

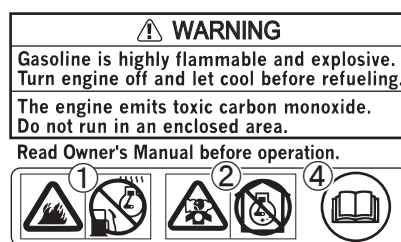

Honda Motor Co., Ltd. MADE IN JAPAN

Honda

- (1) Fire hazard
Stop the engine when refueling. Fire may occur if a flame is near the tank fuel port.
- (2) Danger: poisonous exhaust gas
Carbon monoxide poisoning may occur if the exhaust gas is inhaled. Do not operate the machine in a poorly ventilated area.
- (3) Hot muffler
Do not touch the muffler and its surrounding area.
- (4) Read operation manual
For safe operation, always read the operation manual before use.
- (5) Fire, open flame and smoking prohibited.

5. Specifications

Model	MVH-R60		MVH-120GH [VAS]	MVH-120GR	MVH-150GH	MVH-150GR	MVH-150D	MVH-150D (Silent Type)
Dimensions(mm)								
Overall Length	886		1030 [1120]	1030	1130	1130	1130	1130
Overall Width	350		400	400	430	430	430	430
Overall Height	880		900 [990]	900	920	920	920	920
Plate Size (W x L)	350 x 480		400 x 585	400 x 585	430 x 700	430 x 700	430 x 700	430 x 700
V-Belt Size	RPF-3320		RPF-3320	RPF-3320	RPF-3350	RPF-3350	RPF-3340	RPF-3340
Lubrication Oil in vibration case (cc)	200		350	350	350	350	350	350
Weight								
Operating Weight (kg)	68	69	116 [118]	118	150	161	150	158
Performance								
Max, Travelling Speed	0-25m/min		0-23m/min	0-23m/min	0-25m/min	0-25m/min	0-25m/min	0-25m/min
Vibrating Frequency	100Hz (6000v.p.m)		100Hz (6000v.p.m)	100Hz (6000v.p.m)	90Hz (5400v.p.m)	90Hz (5400v.p.m)	90Hz (5400v.p.m)	90Hz (5400v.p.m)
Centrifugal Force	15kN (1530kgf)		22.5kN (2300kgf)	22.5kN (2300kgf)	27kN (2750kgf)	27kN (2750kgf)	27kN (2750kgf)	27kN (2750kgf)
Power Source								
Manufacturer	Honda	Robin	Honda	Robin	Honda	Robin	Robin	Yanmar
Model	GX120 (petrol)	EX13 (petrol)	GX160 (petrol)	EH17-2D (petrol)	GX200 (petrol)	EH25-2D (petrol)	DY23-2D (diesel)	L48N6-VSMK (diesel)
Max.Output	2.6kW(3.5PS) /3600min ⁻¹	3.2kW(4.3PS) /4000min ⁻¹	3.6kW(4.9PS) /3600min ⁻¹	3.7kW(5.0PS) /4000min ⁻¹	4.1kW(5.6PS) /3600min ⁻¹	5.9kW(8.0PS) /3600min ⁻¹	3.7kW(5.0PS) /3600min ⁻¹	3.5kW(4.7PS) /3600min ⁻¹
Fuel Tank Capacity	2.0L	2.7L	3.1L	3.6L	3.1L	6.0L	3.2L	2.5L
Set R.P.M	3600min ⁻¹ (3600rpm)		3600min ⁻¹ (3600rpm)	3600min ⁻¹ (3600rpm)	3600min ⁻¹ (3600rpm)	3600min ⁻¹ (3600rpm)	3200min ⁻¹ (3200rpm)	3200min ⁻¹ (3200rpm)
Guaranteed sound power level(dB) (in comply with 2000/14/EC)	105	105	108	108	108	108	111	108
Measured sound power level(dB) (in comply with 2000/14/EC)	104	104	107	106	107	107	110	106
Hand Arm Vibration (m/sec²) (in comply with 2002/44/EC)	7.6	7.5	5.5 [2.5]	5.2	8.8	5.8	8.7	9.2

6. Appearance

6-1. Outside Dimension (mm)

MVH-R60

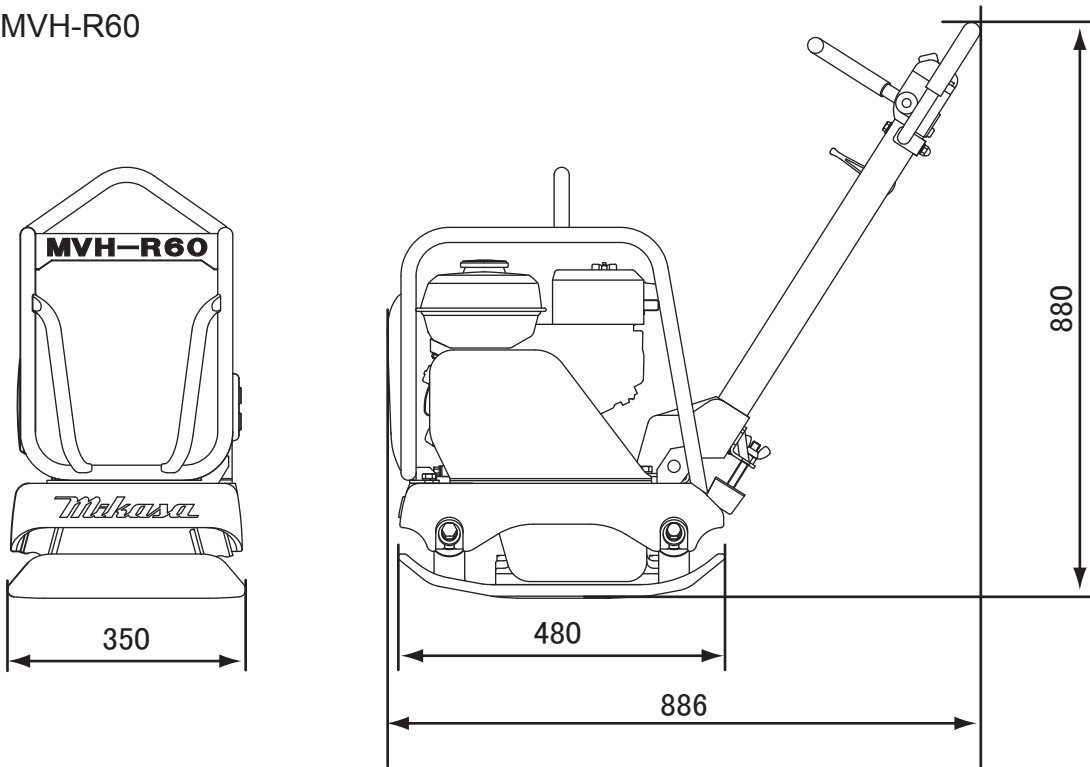

MVH-120
MVH-150

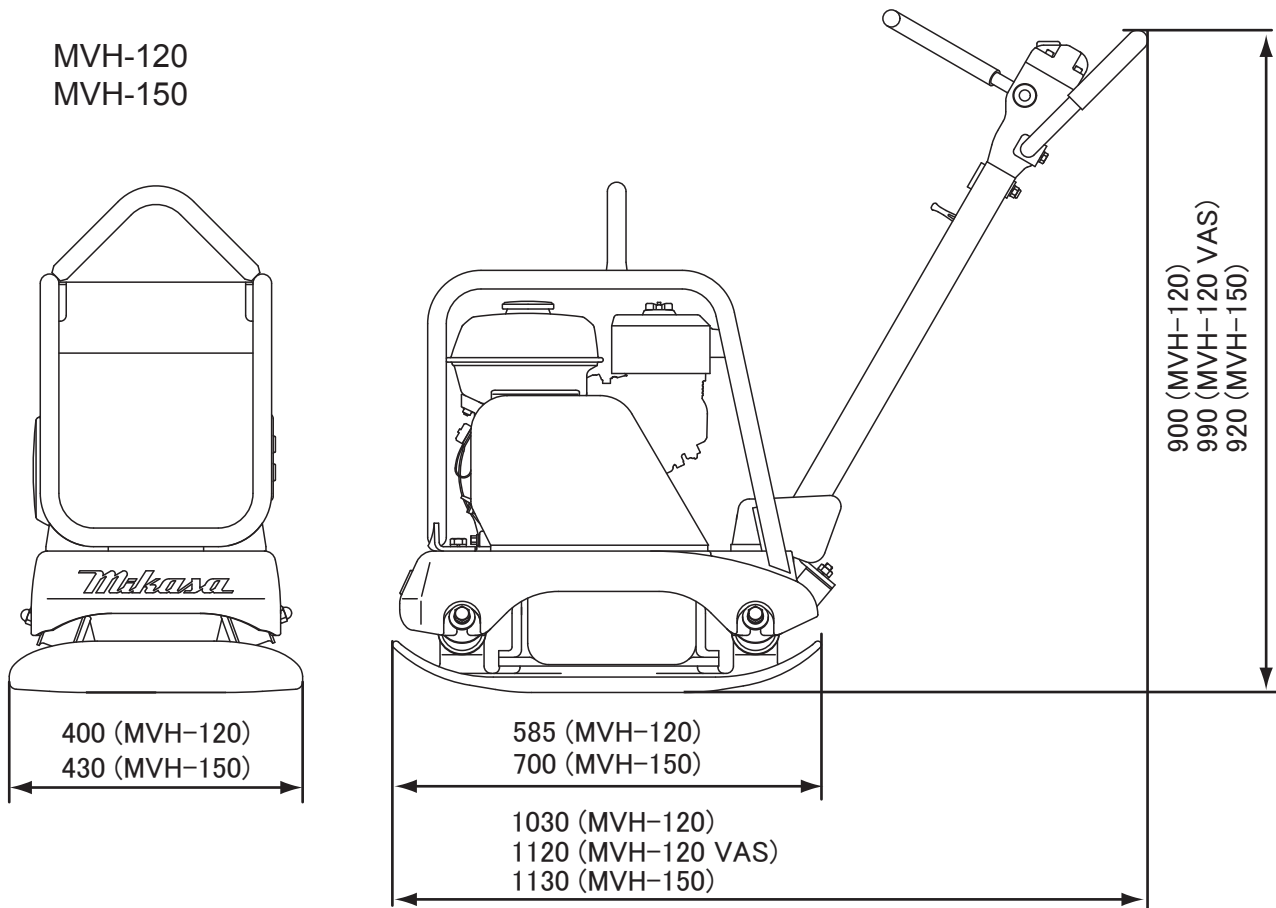

6-2. Parts and Component

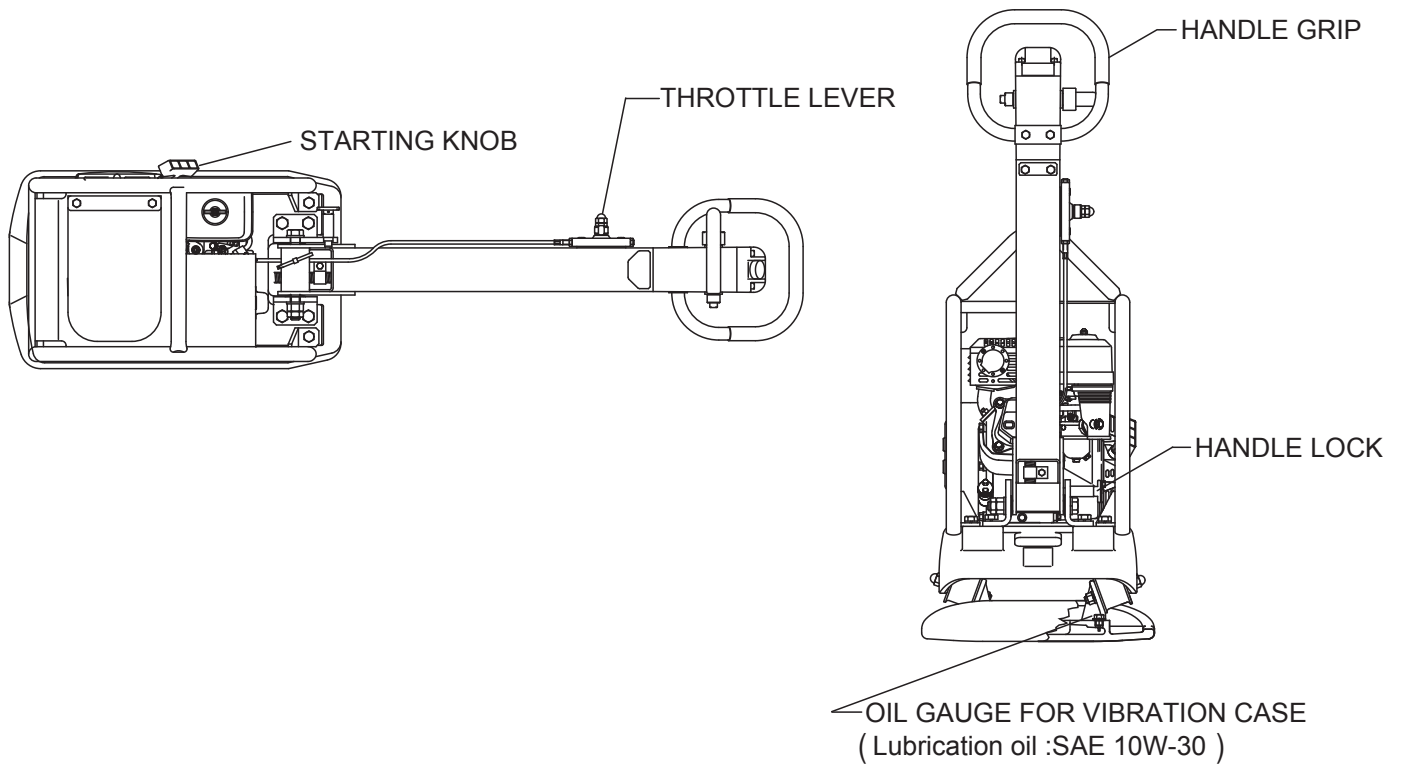
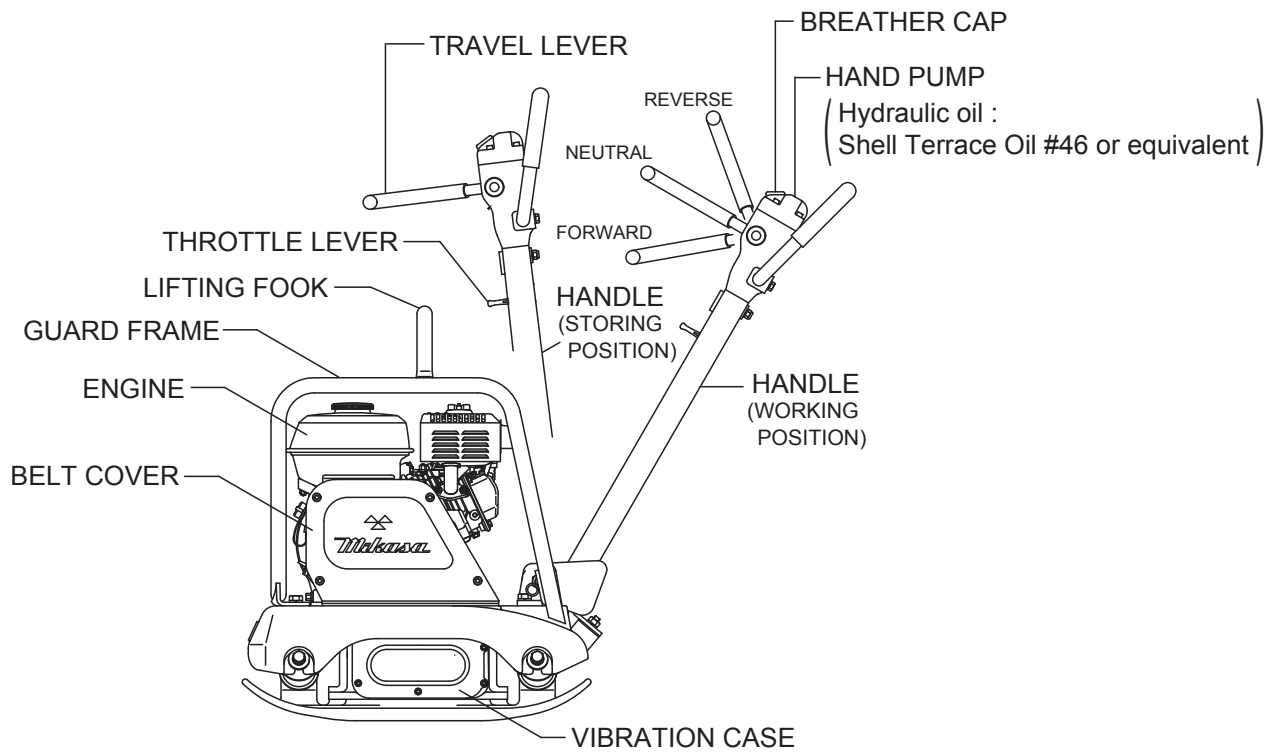

7. Inspection Before Operation

1. Clean each part of the machine well to maintain dirt and dust-free condition. Pay special attention to the soil attached to the bottom of the compacting board, engine cooling air inlet, and the carburetor and air cleaner area to keep those parts clean.
2. Check each part for any looseness of bolts. Vibration causes bolts to loosen, which might result in unexpected accident or malfunction.
3. Inspect the guard hook, belt cover and anti-vibration rubber to check the function of speed adjustment wire and speed adjusting lever.
4. Check for oil leakage from the hydraulic pump and hoses.
5. Check the V-belt tension. (See p.19.) The belt should have about 10–15mm of flexibility when pushed strongly with a finger at the mid-point between the axes. If the V-belt is loosened, power is not transmitted well, which reduces compacting force and shortens the life of the V-belt.

6. Set the engine on a level surface to check the oil level. If the oil level is low, add oil. Use the following engine oil.(Fig. 1)

Quality:

Diesel engine oil, Grade CC or above
Gasoline engine oil, Grade SE or above

Viscosity:

SAE No. 30 at 20°C and above(summer)
SAE10W-30

7. Set the machine on a level surface, then remove the oil gauge of the vibrator. Check the oil gauge to see if the oil is at the specified level. Use engine oil SAE10W-30 as lubrication oil. Recommended oil quantity for MVH-R60 is 200cc and MVH-120/150, 350cc. (Fig. 2)

8. Refueling

⚠ DANGER

- Do not expose to open flames while refueling.
- Do not fill to the rim because the fuel might spill.
- Wipe off well if a spill occurs.

Use clean automotive gasoline or automotive light oil appropriate for the engine. Let the fuel run through a filter when refueling.

OPERATIONAL CAUTION

Prior to OPERATION:

Check engine oil and fuel level.

If not enough, add to proper level.

To START engine:

1. Warm up engine at low speed for 3 to 5 minutes.
2. Operate machine always at full speed to avoid incorrect clutch engagement.
3. Use travel lever for forward and reverse motion. Do not push or pull lever strongly.

To STOP engine:

Move stop switch to "OFF" position.

To LIFT machine by using lifting hook in center

To STORE machine covered with plastic sheet in a moisture.

Do not move travel lever if engine stops (MVH-120/150)

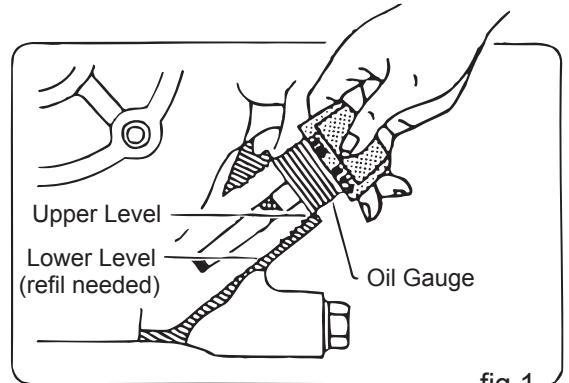
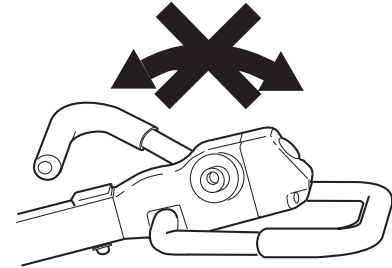

fig.1

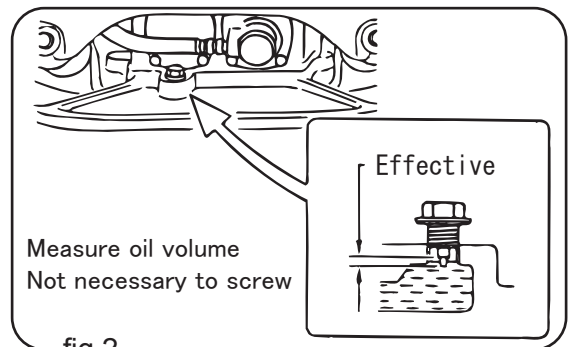

fig.2

8. Operation

8-1. Starting

Gasoline Engine

1. Set the fuel cock lever to the "Out" position to let the fuel flow. (Fig. 3-1, 3-2, 3-3)

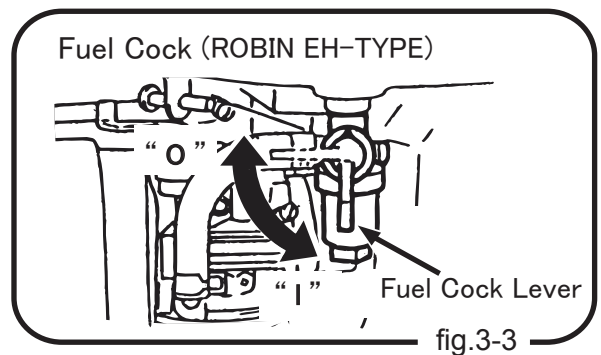
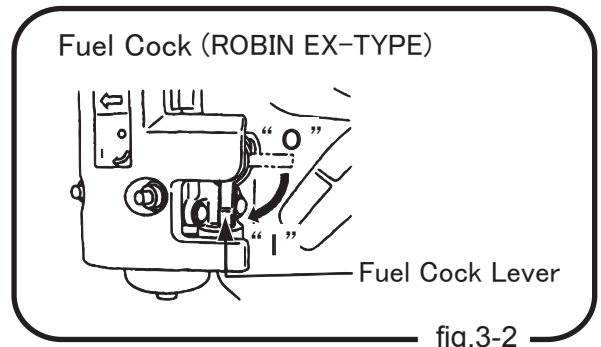
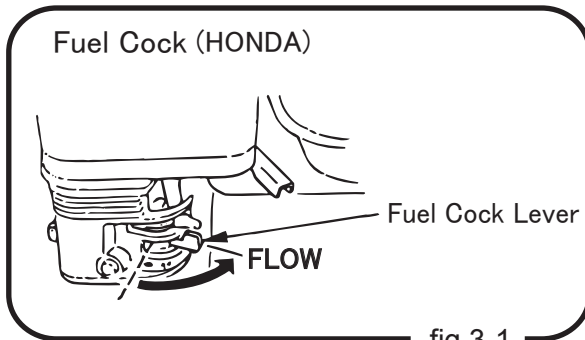

2. In cold weather or when the engine does not start easily, set the choke lever to the "Start" position. This is not necessary when the engine is already warmed up. (Fig. 4-1, 4-2, 4-3)

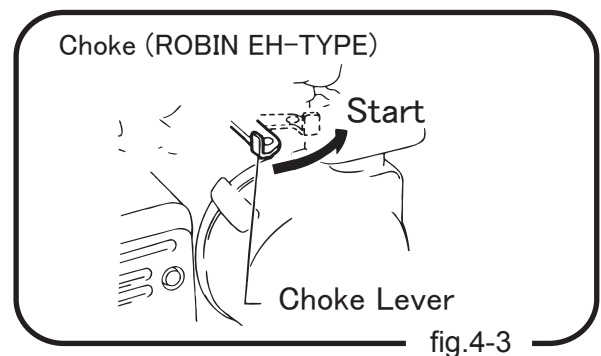
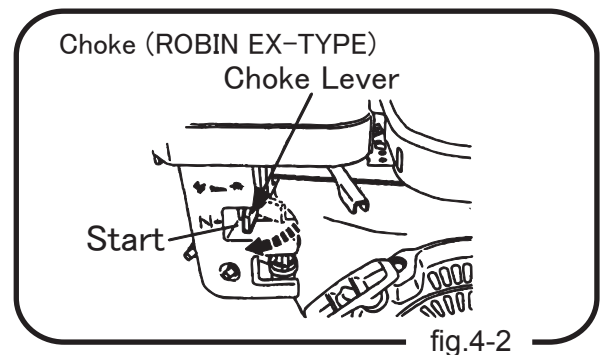
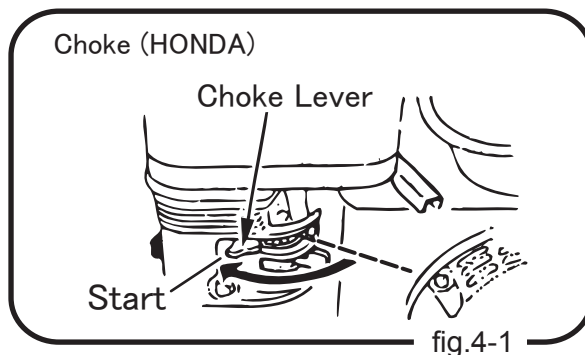

- Slightly move the throttle lever at the handle to high. (Fig. 5)

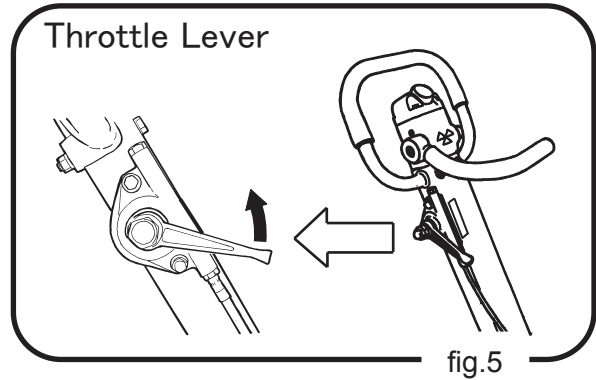

- Turn the engine switch to "ON (operation)". (Fig.6)

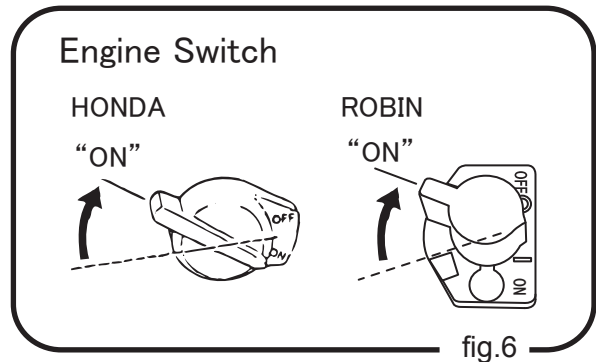

- Hold the recoil starter grip, and pull it a little. You will feel a slight resistance. Then, pull it hard to run the engine. Be careful not to pull too hard, or the rope might break or come off. Allow the starter rope to slowly move back into the case while keeping the grip grabbed. (Fig. 7-1, 7-2)

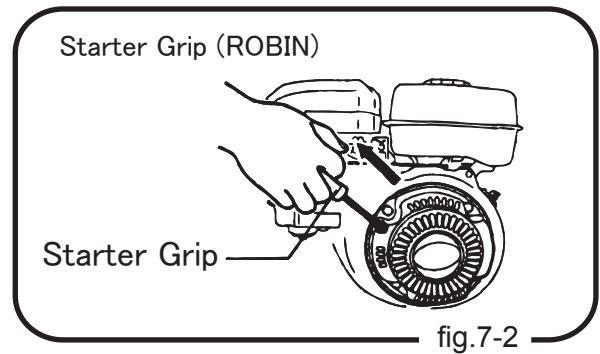
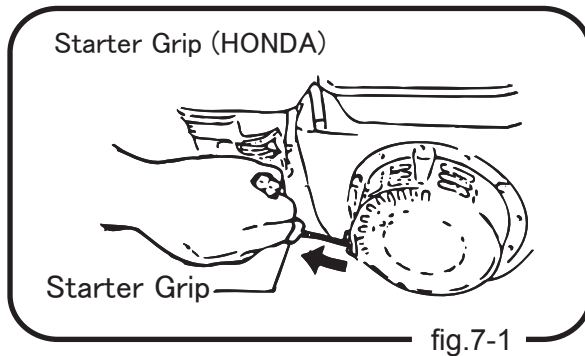

- After the engine has started, while you hear some explosion loud noise, gradually move back the choke lever until it is wide open. (Fig. 8-1, 8-2)

-When the choke lever is set to "Start", gradually move it back toward the "Operation" direction while making sure the engine revolution stabilizes.

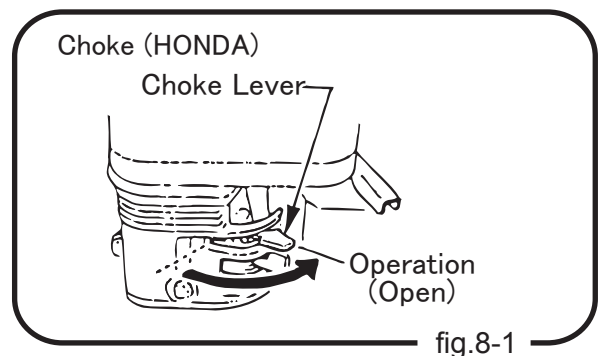

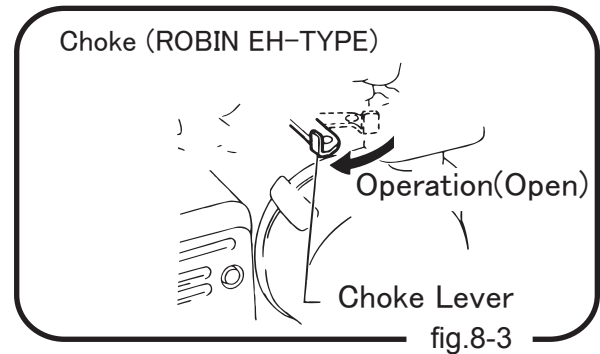
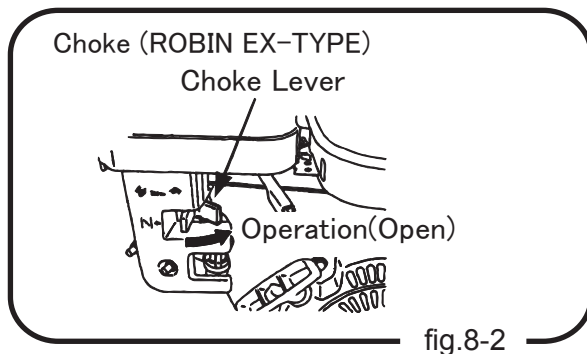

7. After the engine has started, warm up the engine at low speed for 2 to 3 minutes. This is especially important in cold weather. While warming up, check for any abnormalities such as gas leakage.

-After the engine has started, return the speed adjustment lever to the low speed position. If it is left "half open", the centrifugal clutch remains slipping. It might cause the centrifugal clutch to fail, and abnormal vibration of the machine might result and create very dangerous situation.

Diesel Engine (MVH-150D)

1. Open the fuel cock lever. (Fig 9)

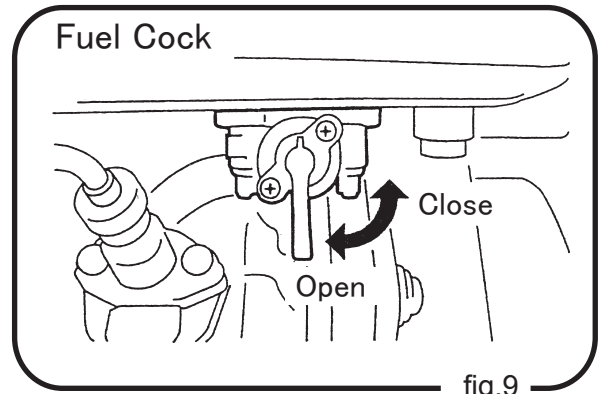

fig.9

2. Open the throttle lever to about 30° for the idling position. (Fig.10)

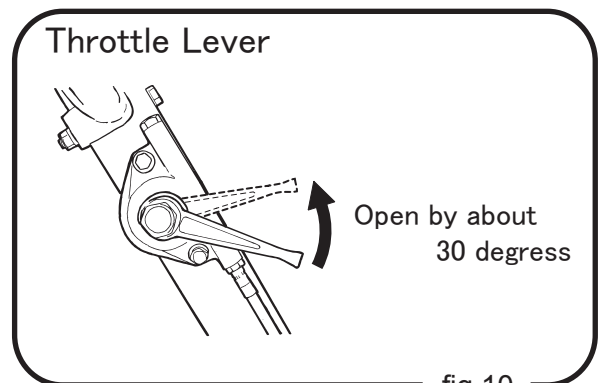

fig.10

3. Recoil starter

CAUTION

Do not pull the rope completely. Allow the start knob to slowly move back while keeping the knob grabbed. If you let the knob off your hand, the rope will suddenly move back, resulting in damage of the knob, engine, or the main body.

- a. If you pull the starting knob slowly, you will feel some resistance at a point (the compression point). After you feel the resistance, slowly return the starting knob.
- b. Push down the decompressor lever.
- c. Pull the starting knob hard to start the engine. (Fig. 11)

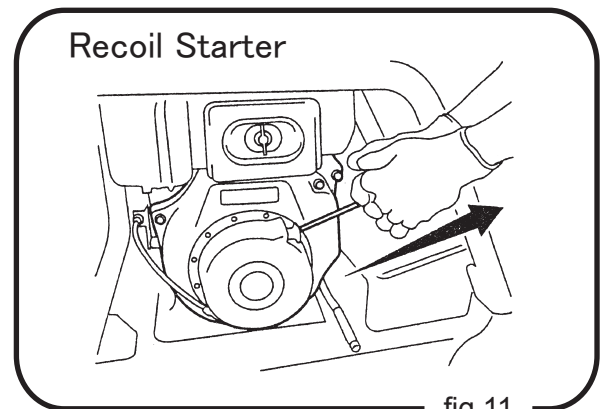

fig.11

4. After the engine has started, warm up the engine at low speed for 2 to 3 minutes. This is especially important in cold weather. While warming up, check for any abnormalities such as gas leakage.

8-2. Operation

⚠ CAUTION

-While the machine is in operation, make sure there is no object or structure that might cause injury or machine damage in the direction that the machine is moving.

1. If the throttle lever is opened suddenly, the machine starts to operate. At an engine revolution of around 2000 rpm, the clutch engages, but if the engine revolution is increased gradually, slipping of the clutch occurs (half-clutching), which results in wear and malfunction of the clutch. So, the operation of the speed adjustment level should be done quickly and suddenly without a hesitation.
2. Use the back and forth travel lever to make the machine move backward and forward. When the lever is pushed forward, the machine moves forward, when pulled backward, the machine moves backward. At neutral, the machine vibrates staying at the same location. (Fig. 12)

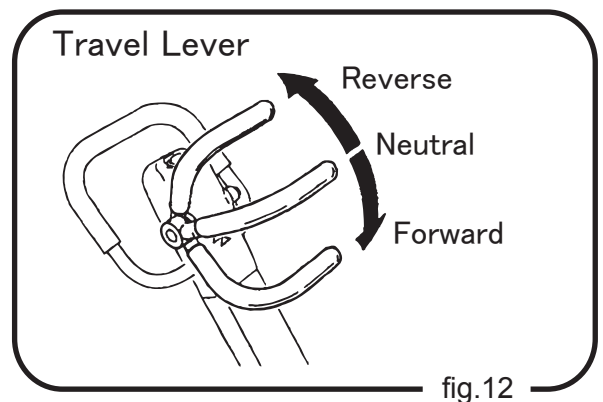

3. When this machine is used on ground that contains clay, the ground surface tends to stick to the compacting board, and the machine travel speed becomes slower. In this case, check the bottom of the compacting board to see if there is any clay adhered to the board. This machine cannot perform well on clay and other type of ground with a high water percentage. Drying the ground is recommended to make the ground water percentage appropriate for the machine to get good compacting performance.

9. Stopping the Machine

1. Move the throttle lever from ON to OFF (for diesel engine, to idle position). Run the engine for 3 to 5 minutes at low speeds to cool it down before stopping.

Diesel Engine

- Move the throttle lever to the stop position to stop the engine.

Gasoline Engine

- Turn the engine switch to the OFF position, then the engine stops. (Fig. 13)

⚠ CAUTION

If the engine is stopped while it is hot, burning of the oil film on the cylinder inner wall occurs, leading to troubles such as accelerated engine wear.

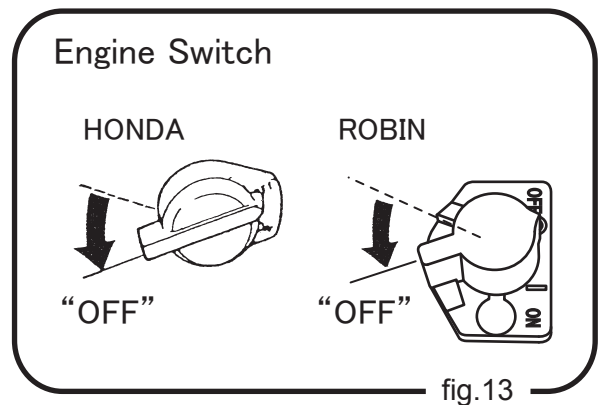

2. For gasoline engine, shut the fuel cock. (Fig. 14-1, 14-2)

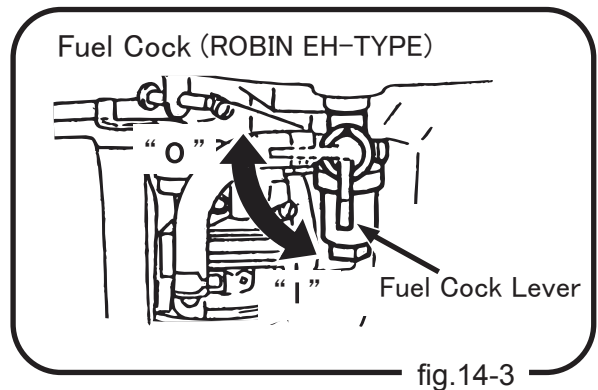
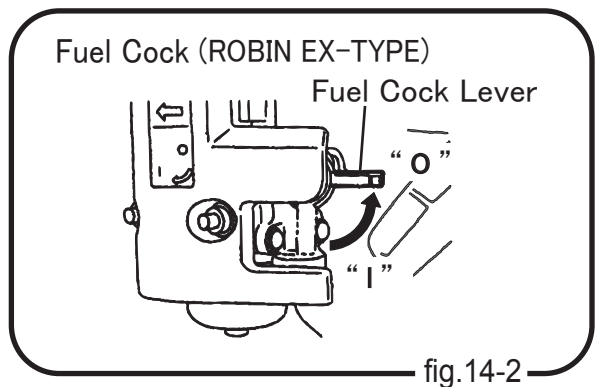
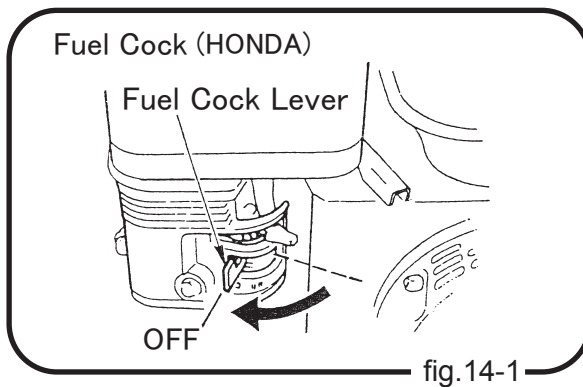

10. Transportation

⚠ WARNING

- Make sure there is no breakage of guard frame and anti-vibration rubber nor loosened or missing bolts.
- Always stop the engine when lifting.
- Use an intact wire rope without any deformation with sufficient strength.
- Slowly lift upward without applying any impact. Never let people or animals go under the lifted machine.
- For safety reasons, do not lift to a height that is higher than necessary.

10-1. Loading and Unloading

For loading and unloading using a crane, an operator qualified for cranes and hooking works is needed.

1. Use a crane for loading and unloading the machine.
2. Designate a person to guide the loading and unloading, and always work under the instruction of that person.
3. When lifting, always use a special hook on the guard frame. (Fig. 15) Never lift by using the hook on the handle.

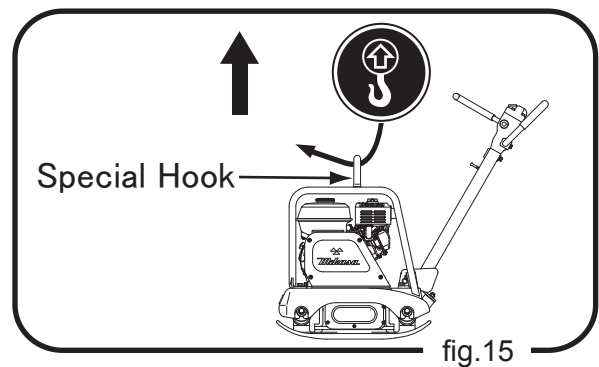

fig.15

10-2. Transportation Precautions

⚠ WARNING

- Stop the engine when the machine is transported.
- Always drain the fuel before transportation.
- Fix the machine securely to prevent the machine from moving or falling.

11. Storage

1. Wash with water to remove any dust and dirt from all parts of the machine.
2. Store in a dry area away from direct sunlight after putting the cover over the machine to prevent dust and dirt buildup.

(When storing for a long period of time)

3. Add fuel and oil or perform an oil change. Remove the battery terminals or remove the battery from the machine for storage.
4. Securely cover the air cleaner and muffler air inlets and exhaust port.
5. Do not leave the machine outdoors. Keep it indoors.

12. Regular Check and Adjustment

12-1. Inspection and Maintenance Schedule Table

Check frequency	Check parts	Check items	Oils
Daily (before starting)	Appearance	Flaw, deformation	
	Fuel tank	Leakage	gasoline
	Fuel system	Leakage	
	Engine oil	Leakage, oil level, dirt	Engine oil
	Shock absorber	Crack, damage, wear	
	Hand pump	Leakage	Hydraulic oil
	Vibrator oil	Leakage	Engine oil
	Hydraulic pipe system	Leakage, looseness, flaw, wear	Hydraulic oil
	Air cleaner	Dust on sponge	
	Guard frame	Breakage, flaw, loosened or missing bolts and nuts	
	Back and forth motion lever, linking parts	Missing, breakage, flaw, looseness or missing bolts and nuts	
	Back and forth motion lever operation	Operation check, play	
Every 20 hours	Bolts and nuts	Looseness, missing	
	Engine oil	Replace only after the first 20 hours	Engine oil
Every 100 hours	Engine oil filter	Replace only after the first 20 hours	
	Engine oil	Change	Engine oil
	Engine oil filter	Washing	
	Vibrator oil	Leakage, oil level, dirt	Engine oil
	Hydraulic oil	Leakage, oil level, dirt	Hydraulic oil
Every 200 hours	Battery terminal	Cleaning	
	V-belt for vibrator	Flaw, tension	
Every 300 hours	Clutch	Dirt, flaw, wear	
	Vibrator oil	Change	Engine oil
	Hydraulic oil	Change	Hydraulic oil
	Fuel filter	Change	
Every 2 years	Engine oil filter	Change	
	Fuel pipes	Change	
Irregular	Air cleaner element	Change	
	Hydraulic hose	Change	

For details about the check and maintenance of the engine, please refer to the attached engine operation manual.

Caution: The above table shows the check frequency for standard condition. The check frequency may vary depending on the condition in which the machine is used.

For check of bolt and nut looseness and tightening, please see the following tightening torque list.

Tightening Torque List (unit: kgf-cm, 1kgf-cm=9.80665N-cm)

		Thread diameter							
		6mm	8mm	10mm	12mm	14mm	16mm	18mm	20mm
Material	4T (SS41)	70	150	300	500	750	1,100	1,400	2,000
	6-8T (S45C)	100	250	500	800	1,300	2,000	2,700	3,800
	11T (SCM3)	150	400	800	1,200	2,000	2,900	4,200	5,600
	When the mating material is aluminum	100	300~350	650~700	(Bolts used on the machine are right-hand thread.)				

12-2. Changing the Engine Oil

Perform the first engine oil change after 20 hours of operation, then change at every 100 hours.

12-3. Cleaning the Air Cleaner

When the air cleaner element becomes dirty, the engine does not start smoothly, and sufficient output cannot be obtained. Machine operation will be affected and the engine life will be shortened greatly. Do not forget to clean the element. (For details, please see the separate engine operation manual.) If the element cannot be cleaned, replace it with a new one.

12-4. Checking/Changing the V-belt and Clutch

1. Check of V-belt (Fig. 16)

At every 200 hours, remove the belt cover (top) to check the tension of the V-belt. The flexibility of the belt should be about 10 mm when pushed strongly with your finger at the mid-point between the axes. When the V-belt is loose, the engine power is not transmitted well, resulting in poor compacting force and shortening the life of the V-belt.

2. Changing the V-belt

- Removing the V-belt

Remove the top and bottom belt covers. Put a wrench (19mm) on the tightening bolt of the vibrator pulley (lower side). Put a piece of cloth at the center of the left side of the V-belt, and pull the belt strongly towards you. While pulling, turn the wrench clockwise, then remove the V-belt.

- Installing the V-belt

Set the V-belt on the lower side of the vibrator pulley. Push the V-belt to the left side of the upper clutch. Similar to removing the V-belt, turn the wrench clockwise to install.

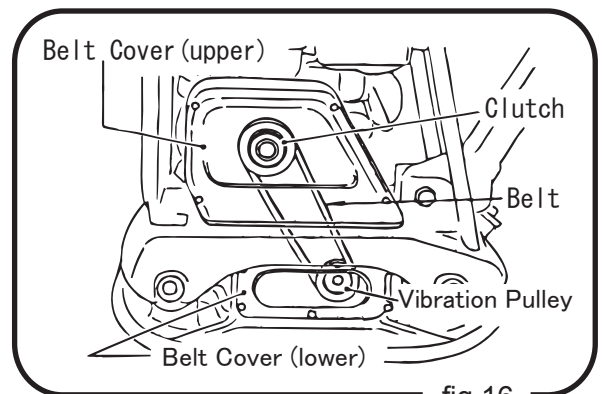

fig.16

⚠ CAUTION

3. Be careful not to get your hand caught between the belt and clutch pulley. Injury may occur. Wear gloves when performing this operation. (Fig. 17)

- Checking the Clutch

Check the clutch when checking the V-belt. Remove the belt cover and check for any seizing on the clutch outside drum. Also visually check for wear and damage on V-groove. If the V-groove is dirty, clean it thoroughly.

Wear on the lining shoe can be checked by an operation check. Wear on the shoe will result in poor power transmission, causing slipping.

To stop the operation, perform the starting steps in reverse. Return the throttle lever quickly and suddenly to lower the revolution speed.

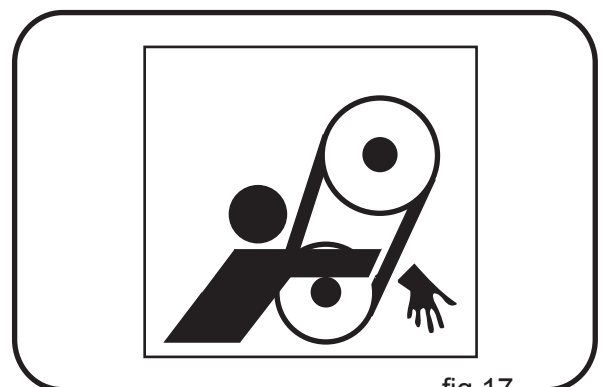

fig.17

4. Changing the Clutch

- Remove the V-belt. (See the belt removing steps described in the previous page.)
- Remove the bolt at the engine output shaft end by applying an impact (hitting with a hammer) to the spanner. (in a counterclockwise direction).
- Remove the clutch with a pulley remover.
- For installation, perform the previous steps in reverse. When tightening the bolt, apply a shock to the spanner to tighten securely.

⚠ CAUTION

If vibration becomes weaker during operation or when there is no vibration even though the engine is running normally, immediately check the V-belt and clutch with disregard to the rule of every 200 hours check.

12-5. Checking/Changing the Vibrator Oil (Fig.18)

At every 100 hours of operation, set the machine on a level surface and remove the oil gauge of the vibrator. Check the oil level to see if it is within the allowable range. (Fig.18)
Change the vibrator oil at every 300 hours operation. Drain the oil from the drain plug. For draining, put a beam under the compacting board at the other side of the drain plug to tilt the machine.

- ※ Use engine oil SAE 10W-3D as lubrication oil. The quantity used is 200cc for MVH-R60 and 350cc for MVH-120/150.

⚠ CAUTION

When checking the vibrator oil, clean the oil port beforehand to prevent dust and other foreign materials from falling into the oil. Whenever there is an oil leakage from the vibrator, check the oil level.

12-6. Checking/Changing the Hydraulic Oil

1. Check the Hydraulic Oil

Check the hydraulic oil at every 100 hours' operation. By making the handle bar vertical (done at the time of storage), remove the breather plug at the top of the hydraulic hand pump to see if the hydraulic oil is at the specified level (OIL LEVEL). (Fig. 19)

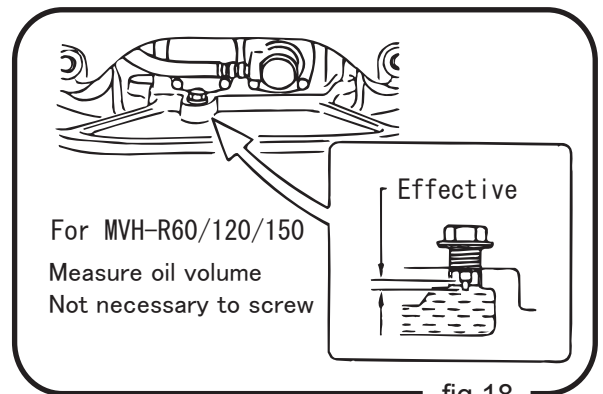

fig.18

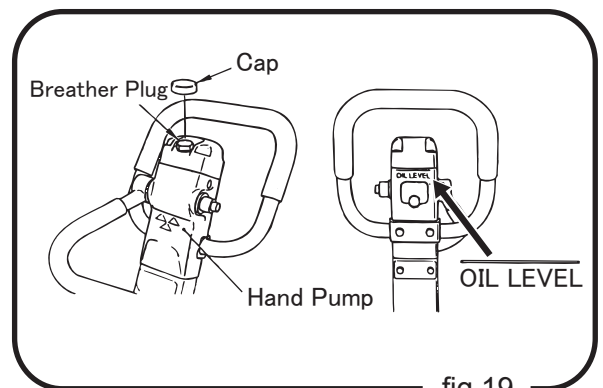

fig.19

2. Changing the Hydraulic Oil (Fig. 20)

⚠ CAUTION

- The level of the hydraulic oil in the hand pump should always be at **OIL LEVEL**. If the level is higher, the oil bursts out from the breather plug.
 - Be careful not to let dust enter inside the hand pump.
- a. Remove the hand pump plug cap, then remove the breather plug (with a 24 mm wrench). Remove the hydraulic hose that is in the vibrator cylinder. Set the lever to the forward motion to drain the hydraulic oil in the pump.
 - b. After the hydraulic oil is drained, install the hydraulic hose to the vibrator.
 - c. Pour hydraulic oil from the hand pump breather plug attachment hole.
(MVH-R60: 0.25L, MVH-120/150: 0.3L)
 - d. Remove the air releasing plug of vibrator cylinder. Then oil will come out from the air releasing plug. After air bubbles stop coming out, attach the plug. Tighten securely.
 - e. Attach the hand pump breather plug, put on the plug cap. After making sure the hydraulic oil in the pump is at **OIL LEVEL**, attach the breather plug.
- **Hydraulic oil: Shell Terrace Oil #46 or equivalent**

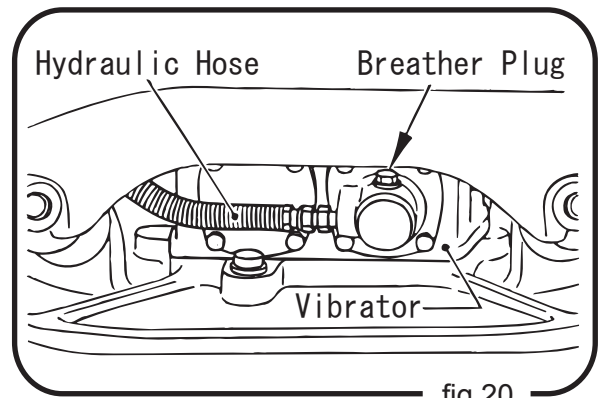

fig.20

13. Troubleshooting

13-1. Gasoline Engine

(1) Starting Problem

- Fuel is supplied, but the igniter plug does not ignite.

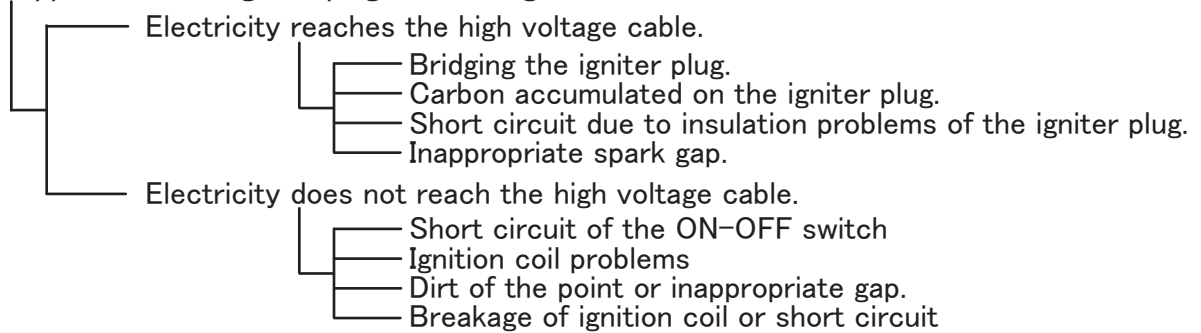

- Fuel supplied, and the igniter plug ignites.

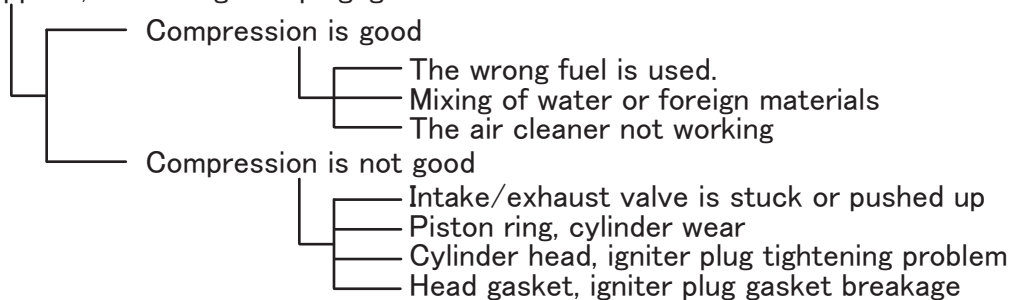

- Fuel does not reach the carburetor.

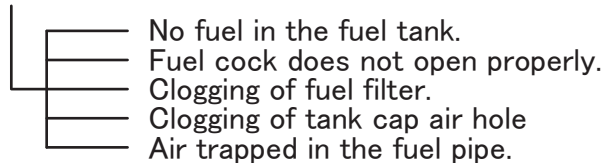

(2) Operation Problems

- Lowered power.

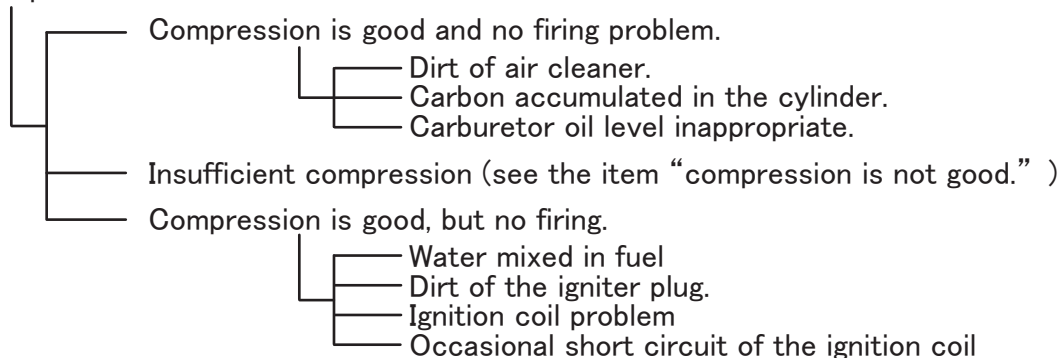

- Engine overheating



- Revolution fluctuation

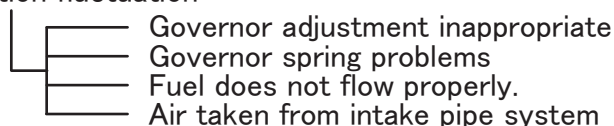

(3) Recoil Starter Operation not Good

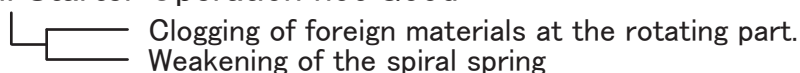

13-2. Diesel Engine

(1) Starting Problem

(A) In case of compression problems

- No compression at all
 - └─ Intake/exhaust valve upthrust
 - └─ Decompressor adjustment problems
- Almost no compression
 - └─ Contact with seat not close enough.
 - └─ Piston ring wear
 - └─ Cylinder wear
 - └─ Cylinder, cylinder head mating surface problems
 - └─ Nozzle seat looseness

(B) In case of inappropriate fuel injection inside the combustion chamber

- Fuel flow low or no flow
 - └─ Clogging of the tank cap air hole.
 - └─ Clogging of the fuel filter
 - └─ Fuel cock not open
 - └─ Air inside the fuel pipe
- Fuel not injected inside the combustion chamber
 - └─ Injection pump barrel, plunger stuck
 - └─ Nozzle hole clogging
 - └─ Nozzle needle stuck
- No fuel in the fuel tank
- Mixing of water or foreign materials

(C) Fuel and compression pressure appropriate, but the engine does not start.

- Does not reach the starting revolution.
 - └─ Inappropriate starting operations
 - └─ Engine oil viscosity high, engine oil is very dirty.
 - └─ Air trapped inside the fuel pipe.

(2) Insufficient Output and Operation Problems

- Insufficient compression
 - └─ See the comment for insufficient compression.
- Engine overheating with black smoke
 - └─ Dirt and breakage of cooling fin
 - └─ Mixing of water inside the fuel filter
 - └─ Carbon accumulated in the combustion chamber or exhaust hole.
 - └─ Smoke set inappropriate
 - └─ Overload
 - └─ Inappropriate injecting timing
 - └─ Nozzle clogging
- Revolution fluctuation
 - └─ Governor fork and sleeve mating surface problems
 - └─ Governor spring problems
 - └─ Fly plate and sliding part wear and operation problems
- Engine revolution does not increase.
 - └─ Valve open/close timing inappropriate
 - └─ Clogged exhaust hole, muffler
 - └─ Overload

- Firing problem with white smoke (when unloaded)
 - ├── Piston, cylinder ring wear
 - ├── Nozzle hole clogging
 - ├── Piston ring stuck
 - ├── Wrong assembly (upside down) of piston ring
 - ├── Inappropriate injection timing
 - ├── Inappropriate valve open/close timing
 - └── Looseness of injection pump joint
- Fuel consumption too high (black smoke)
 - ├── Leakage from fuel passage
 - ├── Clogging of the air cleaner element
 - ├── Inappropriate fuel due to mixing of impurities
 - └── Overload
- Extensive wear on sliding parts or stuck piston rings
 - ├── Use of wrong oil
 - ├── Failure to change oil
 - └── Breakage of the air cleaner element or failure to clean the air cleaner
- Stopped suddenly with abnormal noise
 - └── Searing or damage of the piston, rod, etc.
- Lubrication oil diluted and increased.
 - └── Wear on the injection pump barrel or plunger
- Engine does not stop even though the fuel supply is cut (or over-running)
 - ├── Too much oil
 - ├── Wrong assembly of the governor system
 - └── Detached injection pump rack

13-3. Main Body

- Low travel speed and vibration weak
 - ├── Insufficient engine output and inappropriate high speed set revolution
 - ├── Slipping of clutch
 - ├── Slipping of V-belt
 - ├── Too much vibrator oil
 - └── Failure inside vibrator
- Move forward or backwards, but unable to switch between back and forth motion
 - ├── Hand pump problems
 - ├── Inappropriately installed forward/backward motion lever
 - ├── Breakage of the oil hose
 - ├── Mixing of air in the hydraulic oil
 - ├── Clogging of foreign materials in the check valve inside the hand pump
 - └── Breakage of the piston bearing in cylinder
- No forward, backward motion
 - ├── V-belt coming off, slipping and breakage
 - ├── Slipping of the clutch
 - ├── Locking of the vibrator
 - └── Breakage of the piston bearing in cylinder
- Movement of lever heavy
 - ├── Piston inside the hand pump not moving smoothly
 - └── Vibrator cylinder piston does not move smoothly



6 - 10 Parkway Drive, Mairangi Bay, Auckland 0632
Ph: 09 443 2436 Auck Ph: 03 341 6923 Chch

www.yrco.co.nz



MIKASA SANGYO CO.,LTD.

HEAD OFFICE
NO. 4-3. 1-CHOME, SARUGAKU-CHO, CHIYODA-KU
TOKYO, JAPAN